

Silicon NPN Power Transistors

2SD1398

DESCRIPTION

www.datasheet4u.com

- With TO-3PN package
- Built-in damper diode
- High voltage ,high reliability
- High speed switching

APPLICATIONS

- For TV and CRT display horizontal output applications

PINNING

PIN	DESCRIPTION
1	Base
2	Collector;connected to mounting base
3	Emitter

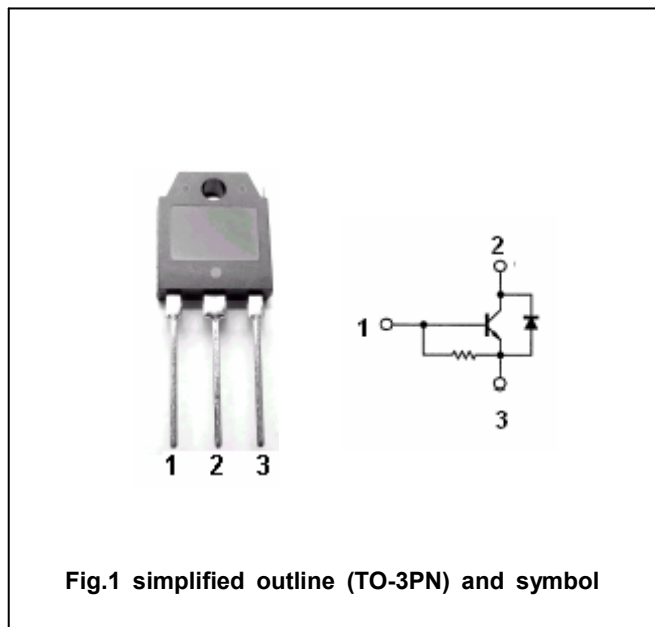

Fig.1 simplified outline (TO-3PN) and symbol

Absolute maximum ratings (Ta=25°C)

SYMBOL	PARAMETER	CONDITIONS	VALUE	UNIT
V _{CBO}	Collector-base voltage	Open emitter	1500	V
V _{CEO}	Collector-emitter voltage	Open base	800	V
V _{EBO}	Emitter-base voltage	Open collector	7	V
I _C	Collector current (DC)		5	A
P _C	Collector power dissipation	T _C =25°C	120	W
T _j	Junction temperature		150	°C
T _{stg}	Storage temperature		-55~150	°C

Silicon NPN Power Transistors

2SD1398

CHARACTERISTICS

T_j=25°C unless otherwise specified

www.datasheet4u.com

SYMBOL	PARAMETER	CONDITIONS	MIN	TYP.	MAX	UNIT
V _{CEO(SUS)}	Collector- emitter sustaining voltage	I _C =100mA; R _{BE} =∞	800			V
V _{(BR)CBO}	Collector-base breakdown voltage	I _C =5mA; I _E =0	1500			V
V _{(BR)EBO}	Emitter-base breakdown voltage	I _E =200mA; I _C =0	7			V
V _{CEsat}	Collector-emitter saturation voltage	I _C =4A; I _B =0.8A			5.0	V
V _{BEsat}	Base-emitter saturation voltage	I _C =4A; I _B =0.8A			1.5	V
I _{CBO}	Collector cut-off current	V _{CB} =800V; I _E =0			10	μA
I _{EBO}	Emitter cut-off current	V _{EB} =4V; I _C =0	40		130	mA
h _{FE}	DC current gain	I _C =1A ; V _{CE} =5V	8			
f _T	Transition frequency	I _C =1A ; V _{CE} =10V		3		MHz
V _F	Diode forward voltage	I _{EC} =5A			2.0	V

Silicon NPN Power Transistors

2SD1398

PACKAGE OUTLINE

www.datasheet4u.com

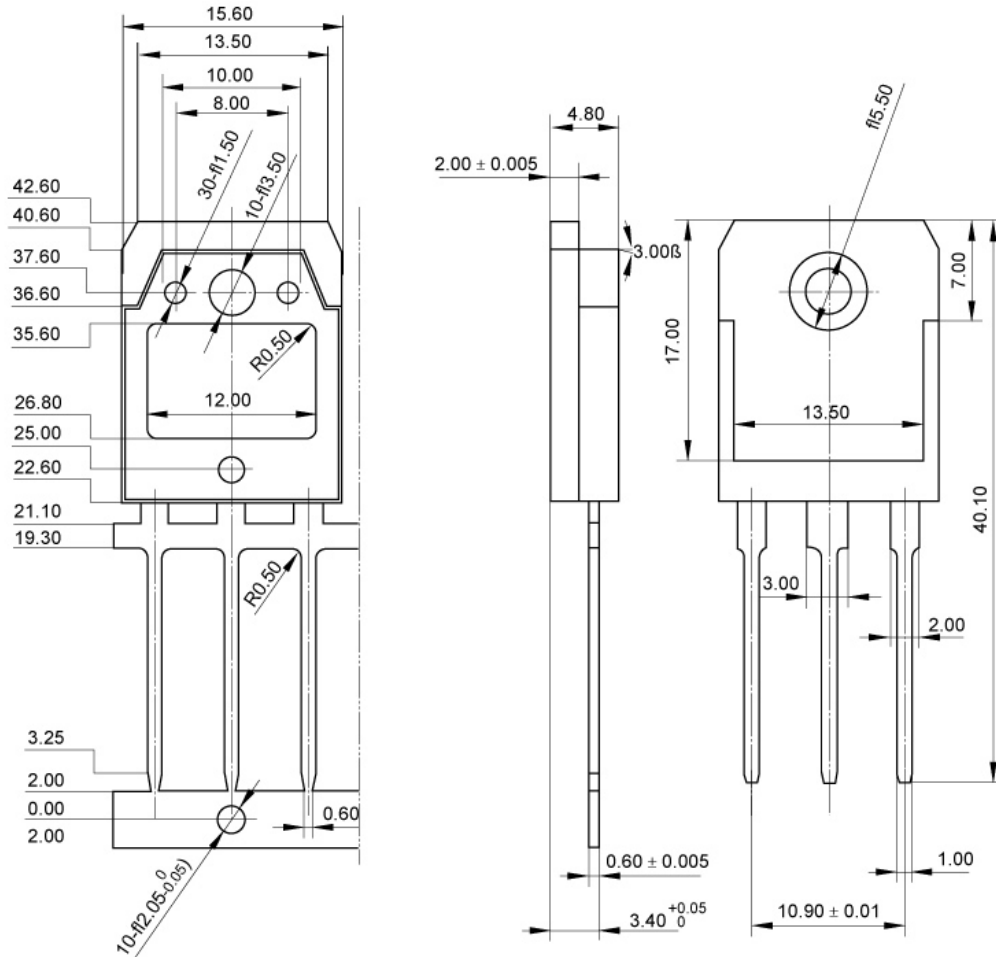

Fig.2 outline dimensions (unindicated tolerance:±0.10 mm)